

# Eclipse Cross-Flow Recuperators

Model CFR121

Version 1

Parameter		Specification*
Recuperator	Maximum Input	14.0 MM BTU/hr (4100 kW)
	Maximum Exhaust Temperature with No Combustion Air	1800°F (1000°C)
	Maximum Exhaust Temperature with 3,550 scfh Combustion Air	2100°F (1150°C)
	Air Pressure Drop at Maximum Input	10.5" w.c. (26 mbar)
	Exhaust Pressure Drop at Maximum Input	1.7" w.c. (4.2 mbar)
	Weight of Recuperator	1400 lbs (635 kg)
Eductor	Suction at Maximum Input at Eductor Inlet	1.7" w.c. (4.2 mbar)
	Entrainment Air Volume at Maximum Input	180,000 scfh (5040 Nm <sup>3</sup> /hr)
	Entrainment Air Pressure at Eductor Inlet at Maximum Input	20" w.c. (50 mbar)
	Weight of Eductor	476 lbs (216 kg)

\* See Design Guide 530 for application specific operational limitations.

- All inputs based upon gross calorific values.
- Eclipse reserves the right to change the construction and/or configuration of our products at any time without being obligated to adjust earlier supplies accordingly.

## Percent Fuel Savings at Given Furnace Exhaust Temperatures and Combustion Air Preheat Temperatures (10% Excess Air)

Furnace Exhaust Temperature °F (°C)	Preheated Air Temperature, °F (°C)				
	700 (370)	800 (425)	900 (480)	1000 (540)	1100 (590)
2400 (1315)	29%	32%	35%	38%	41%
2200 (1200)	26%	29%	31%	34%	36%
2000 (1090)	23%	26%	28%	31%	33%
1800 (980)	21%	23%	26%	28%	31%
1600 (870)	19%	22%	24%	26%	28%
1400 (760)	18%	20%	22%	24%	26%
1200 (650)	17%	19%	21%	23%	25%
1000 (540)	15%	18%	20%	-	-

**Specifications**

**121 Tube Cross Flow Preheated Air Temperature**

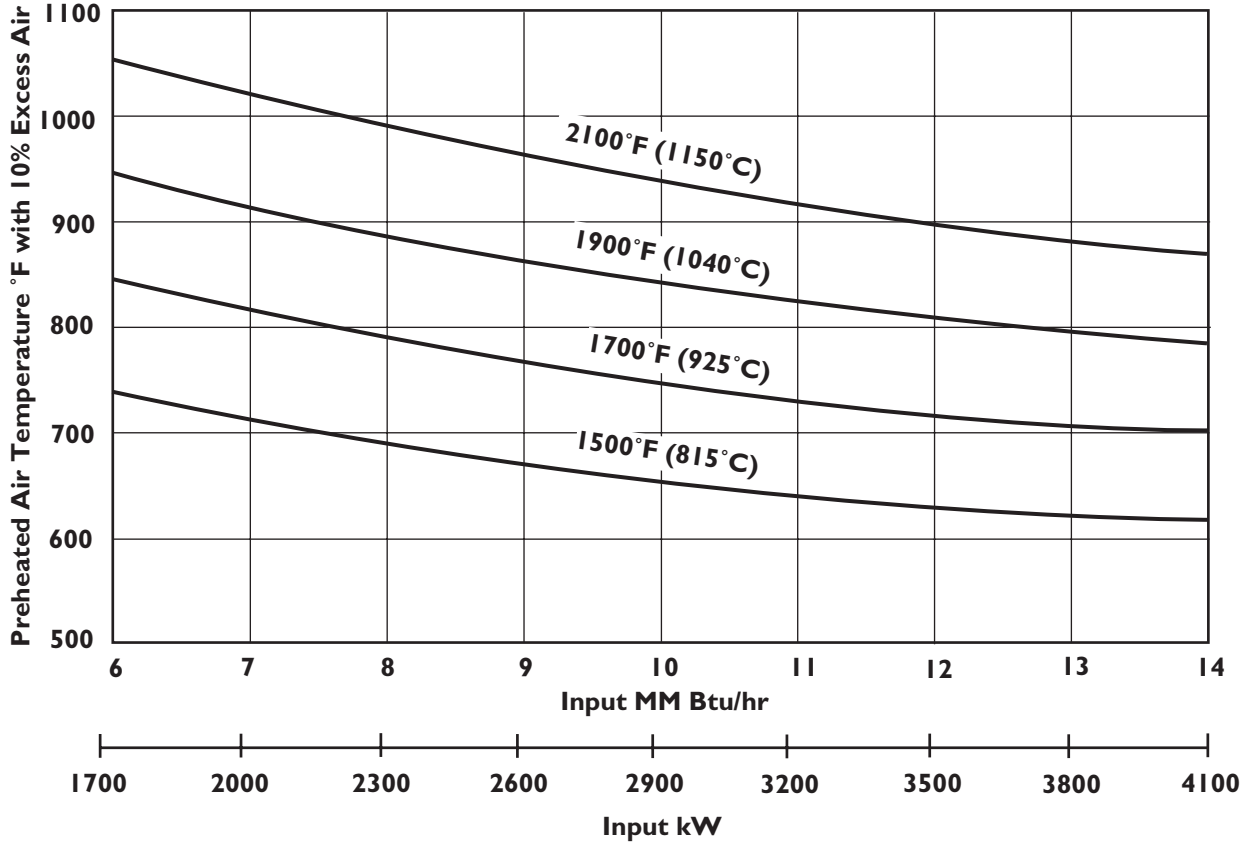

**ΔP 121 Tube Cross Flow with 1900°F (1040°C) Exhaust**

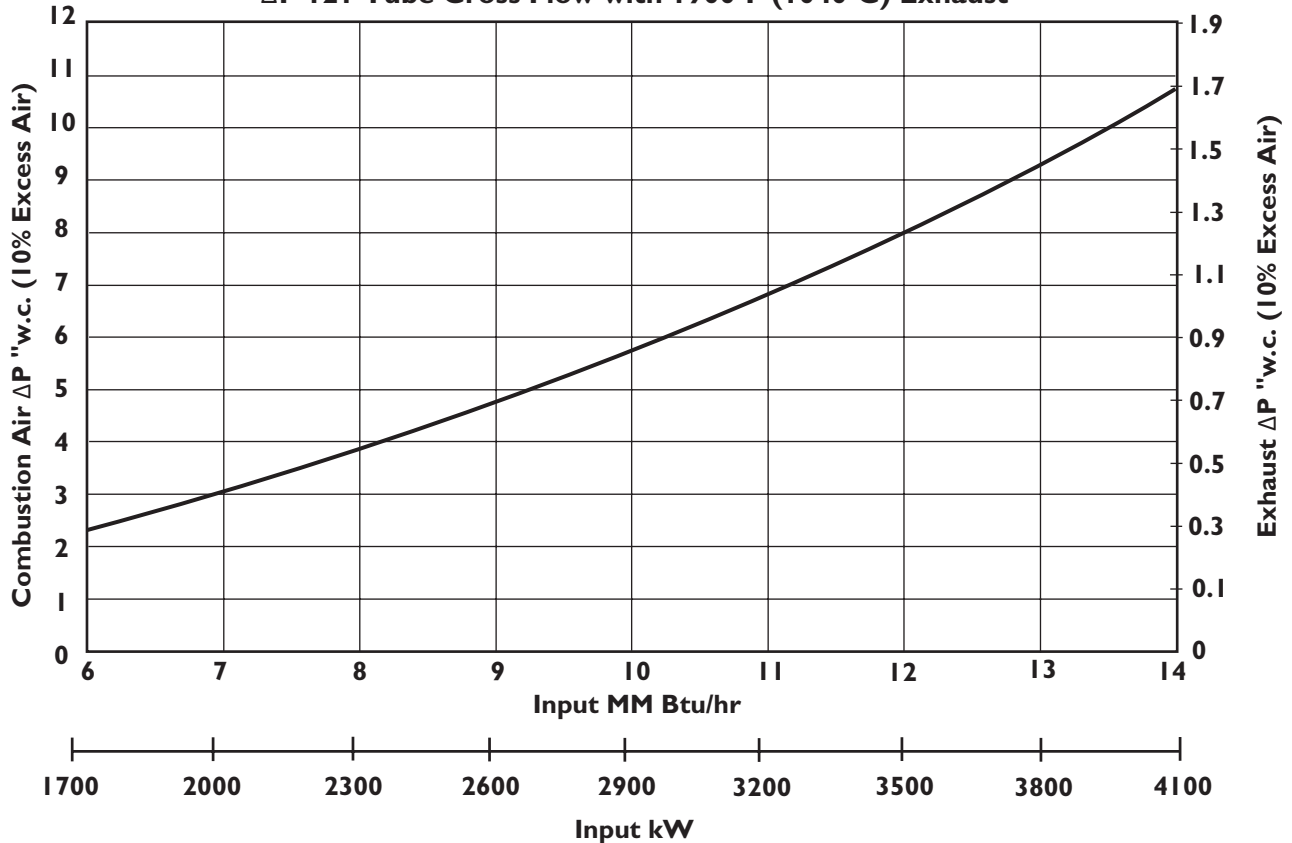

**Dimensions in inches (mm)**

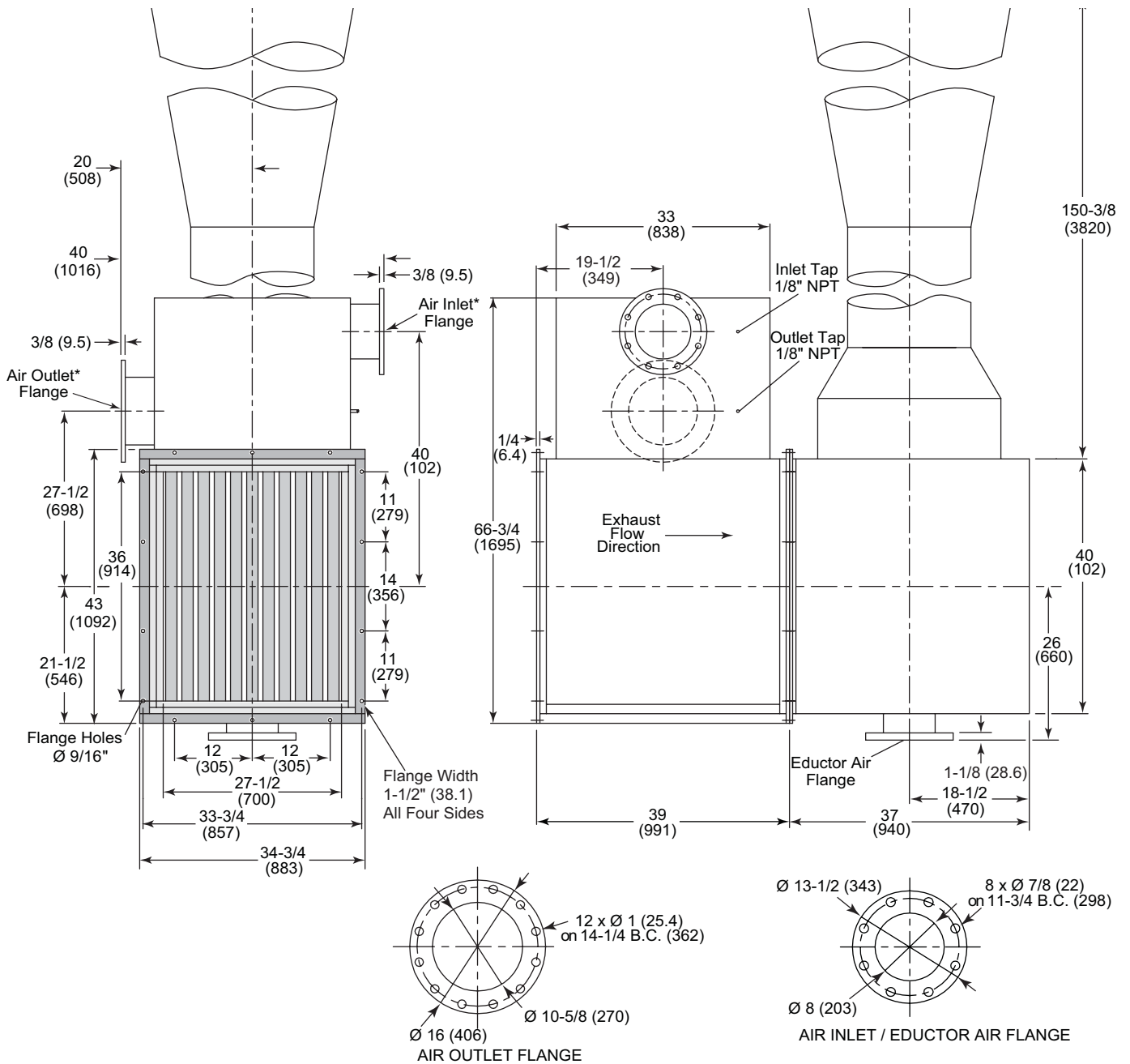

\* NOTE: The air inlet and outlet can be relocated to the opposite side by reversing the CrossFlow recuperator. This will not affect the recuperator performance.



**Offered By:**

Power Equipment Company  
2011 Williamsburg Road  
Richmond, Virginia 23231  
Phone (804) 236-3800  
Fax (804) 236-3882

---

[www.peconet.com](http://www.peconet.com)